

You of I (Somewhere...)

Lucid Dreams  
REM Dreams  
Day Dreams

Manifestations = Strategic Mathematical Traction on  
Purpose

Visions = Mathematical Traction / Projection (Based on the highest  
probability of current calculations based on Logic, Math, and  
Physics)

Life Titans

Conscious Awareness = Days Dreams = "Manifestation"  
Identity = REM = "Dreams"  
Logic (Our Creation Intuition) Manifestations = Lucid Dreams

Deja Vu = Manifestation of our Logical Lucid Dreams coming to  
Fruition, BUT... because they are not part of our Conscious  
Awareness, we are surprised when "it comes back around"

Logic = Intuition

"Manifest"

Applying strategic Conditioning of my own RAS DURING REM and Lucid Dreaming states so I can MAXIMIZE my own intelligent and knowledge without the use of TIME, DRUGS, or books...

"Show me the next step."

"I WANT THE SOLUTION TO EX."

POWER

1  
2  
3

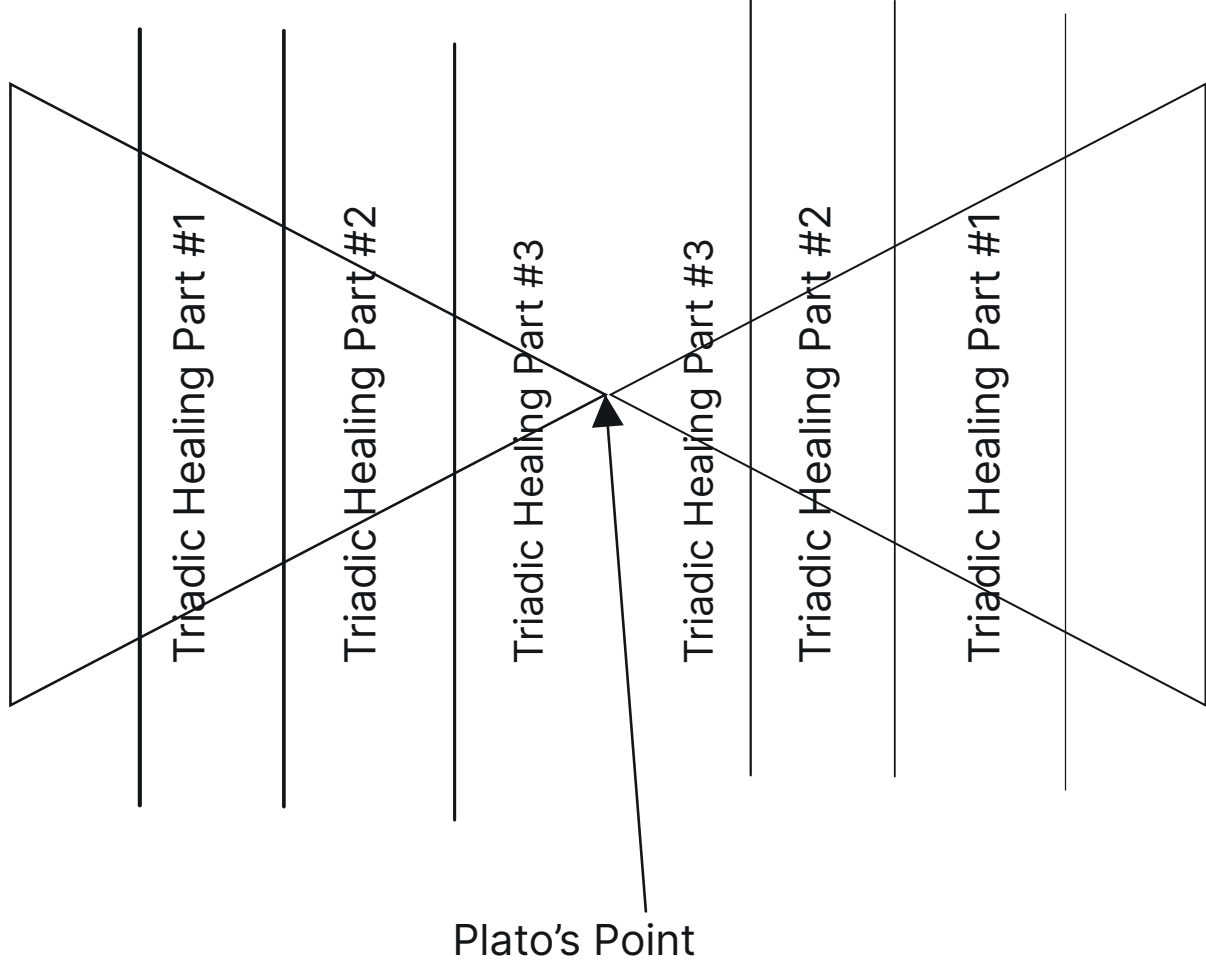

Love = Power

Want

Choose

Purpose

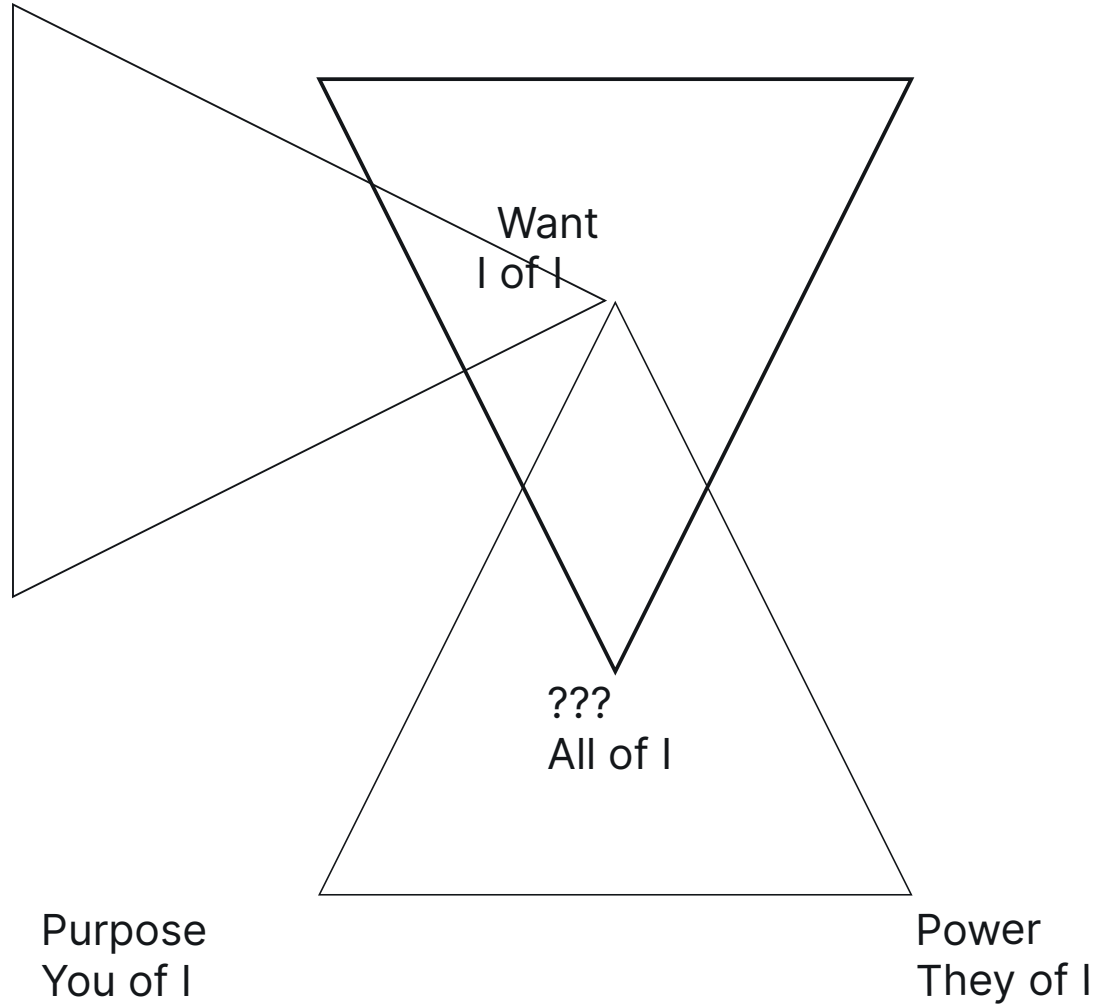

It is in the Choosing and the Practicing of our QUALITIES that we BECOME

Want = Purpose = love

PROCESS of becoming = Power  
"Proof of concept"

Power is Acting out of Love

What qualities do I WANT

Purpose  
LOVE

What kind of a person do you Want TO BE?

What qualities DO YOU WANT

For yourself?  
"Instead of saying "I can't..."  
Say How can I become?"

Momentum  
Generator  
Want Choose Do = Power

BECOME the Qualities

I AM  
POWER (LOVE)

DO the Qualities

Action  
Choice

Practicing your QUALITIES

100% Socrates = Written by Plato  
Was Socrates a figment of Plato's Imagination?

I am therefore I think - Kant  
I think therefore I am - Descartes  
I love therefore I do therefore I am - Anna

To be is to think  
To think is to be

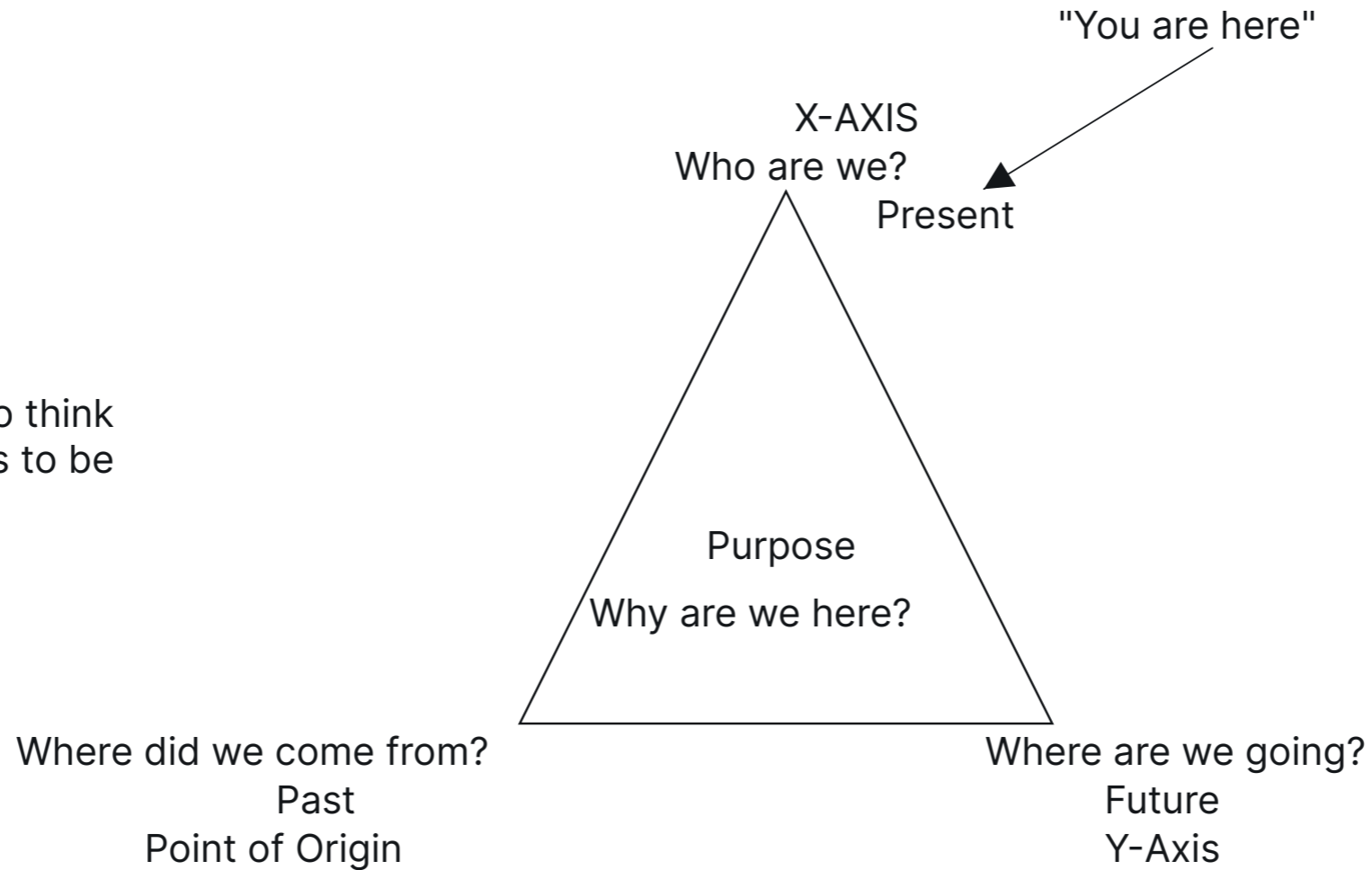

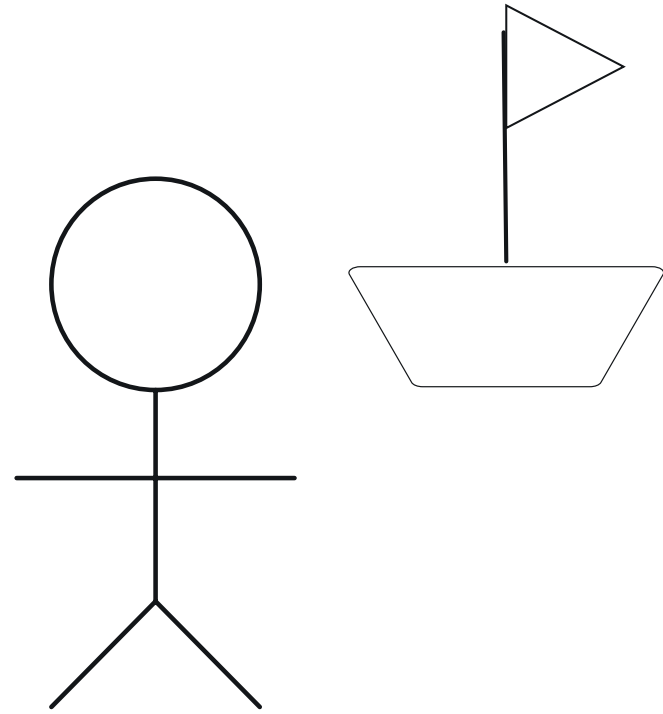

Stage #1  
THE BUILDING of your Boat  
(AT HOME 0 - 5)

What kind of boat  
Are you going to build?

1 - 2 - 3  
Learn how to BE Physics

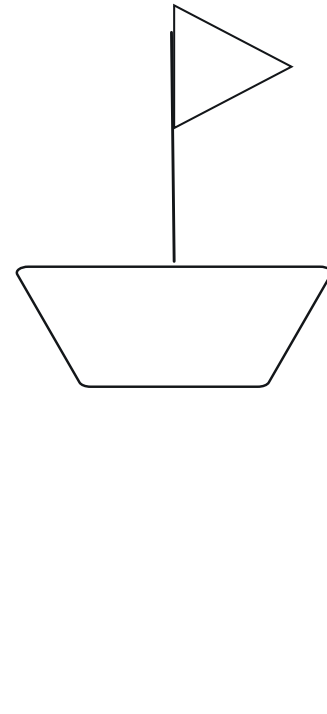

Stage #2  
PLOTTING YOUR  
DESTINATION  
At School LEARNING  
EDUCATION = LIFE SAILING  
LESSONS SO YOU CAN  
CAPTAIN YOUR SHIP  
4 - 5 - 6  
"How not to be an asshole"  
Becoming aware that you ARE PHYSICS

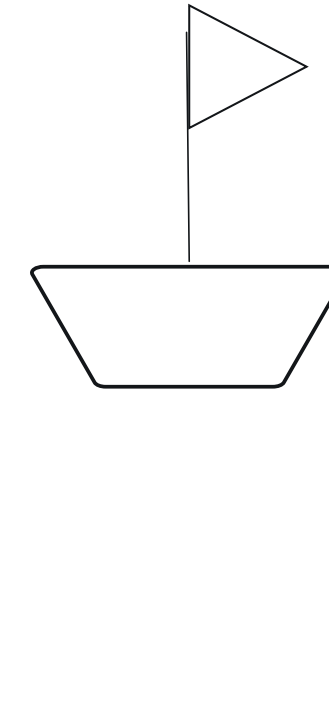

Stage #3  
SET SAIL WITH YOUR BOAT  
"BON VOYAGE"  
IN LIFE

7 - 8 - 9  
POWER ECONOMICS  
Human circuitry

"You don't get POWER until you  
Learn to respect THE POWER OF OTHERS."  
- The Ethical Genius of Mother Nature

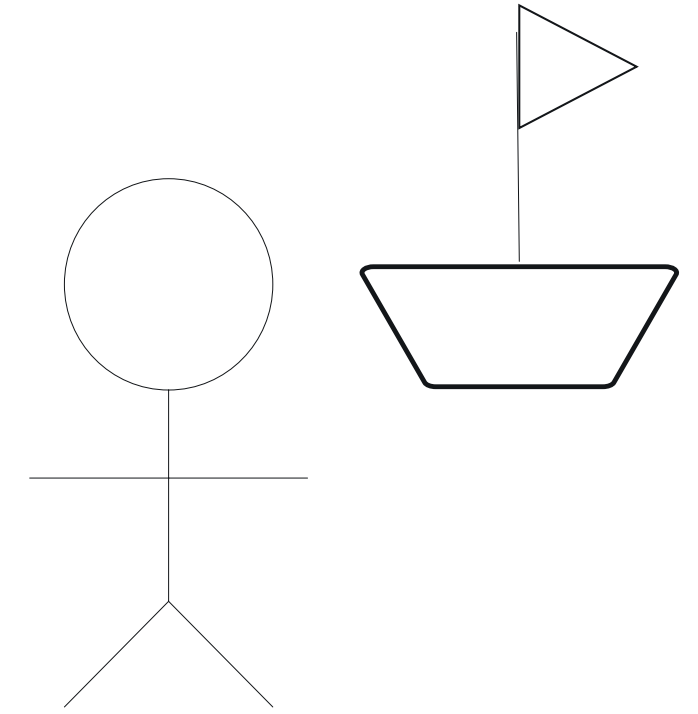

Stage #4  
MASTERING THE SEAS  
WITH STEERING  
"FLEET BUILDING 101"

10, 11, 12  
NAVIGATION AND STEERAGE

# GENERATOR (ENGINE)

Want + Choose + (Learn + Solve) + Do = POWER

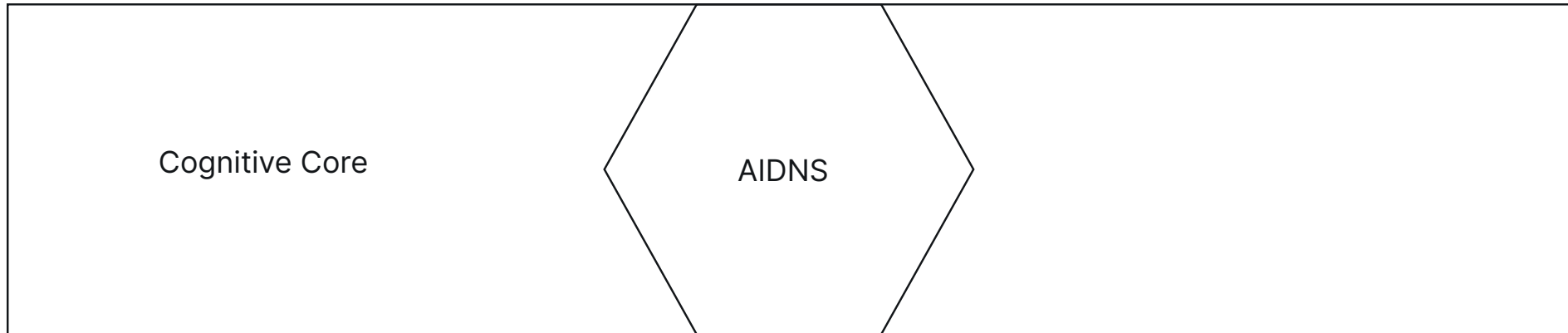



Install (Upgrade) the AIDNS = Logical Information  
(Learning about it)

AIDNS + Cognitive Core = Prosthetic Subconscious Mind  
Abstract Intra-Dimensional Navigational System

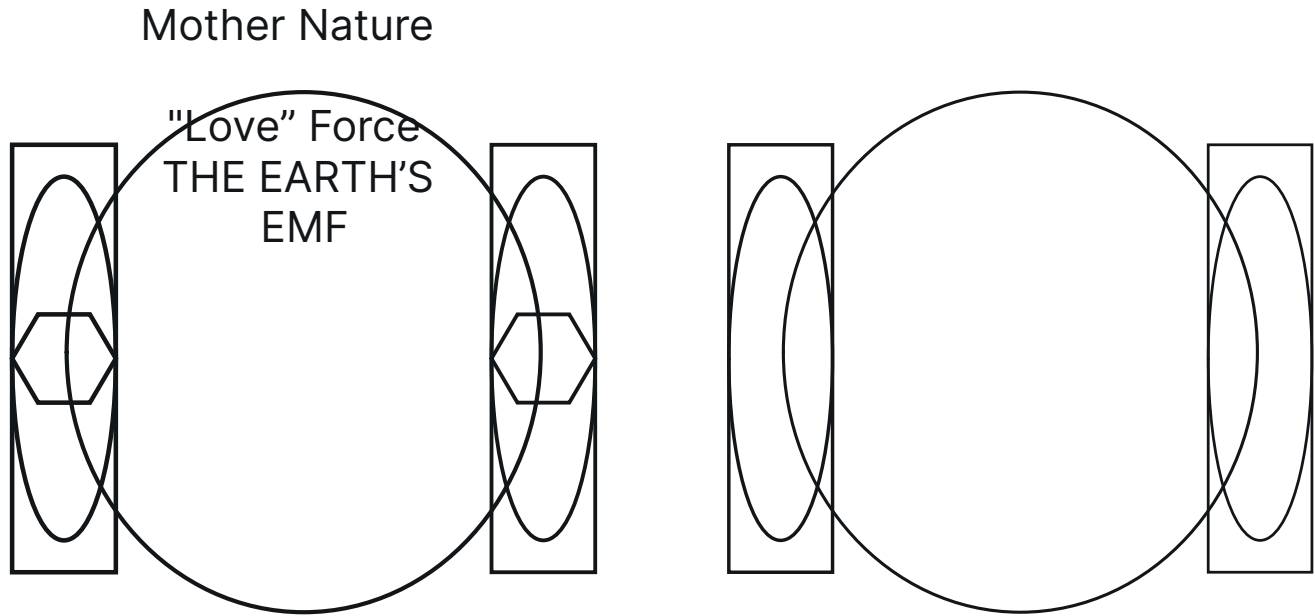

POWER ECONOMICS = GENERATOR TO POWER MY BOAT

A MOTOR! For my ship!

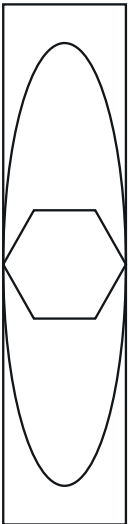

In Growth Mode  
PERSONAL EMF

INTERFERENCE with your  
NATURAL FREQUENCY

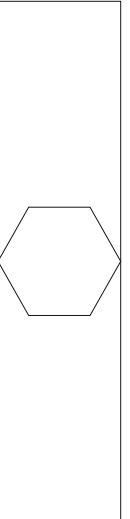

NOT In Growth Mode

- Aging
- ADHD
- Mental Illness
- Ignorance
- Amnesia
- Short Term Memory Loss
- Physical Illness
- Cancer

Scientific Method +> Your Path of Learning and Exploration

Learning = Scientific Method

1+1=2  
Jack has a ball. = 1 Clause = 1 Sentence  
Jack has a Bat. = 1 Clause = 1 Sentence  
Jack has a Ball and a Bat. = 2 Clauses ⇒ 1 Sentence

The First Law of Integrated Mathematics:  
An Integrated Whole is ALWAYS DEPENDENT upon it's components

Second Law of Integration: A UNION DIVIDED AGAINST ITSELF

[Learning (Scientific Method) 1+>12+>Infinity] + [Want + Choose + Do] + Power Economics [Purpose (Power) + Destination (Goal)] = Strategic Life Planning and Propagation +> Success and Happiness and Prosperity

CANNOT STAND

**Component #1**

[Learning (Scientific Method) 1+>12+>Infinity]

**Component #2**

+ [Want + Choose + Do] +

**Component #3**

Power Economics [Purpose (Power) + Destination (Goal)]

**INTEGRATED (GREATER) WHOLE**

= Strategic Life Planning and Propagation +> Success and Happiness and Prosperity

Educated "Integrated" Thinkers = ALWAYS INTEGRATE  
Non-Integrated Thinkers = NEVER or RARELY INTEGRATE

Sum or Summation

+

A = Peach



INDEPENDENT

3 Peaches

Peach = It's OWN Self

A+A+A = 3A

1+1+1 = 3

DEPENDENT AND INDEPENDENT

Integration Math

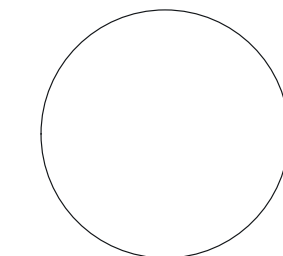

James' Peach



1+>1+>1 //1

3 //1 (ALWAYS

Dependent upon its components)

YOU ARE AN INTEGRATED WHOLE

Mental Illness is when an INTEGRATED WHOLE IS DIVIDED  
AGAINST ITSELF

WE ARE PHYSICS

Cultivates DISINTEGRATION OF THE SELF

Learning and Education = Mental HEALTH = Logical Health + Story Health + POWER ECONOMICS = WE  
ARE PHYSICS

Right INFORMATION

Follow The Correct Mathematical Sequencing = Order of Operations

The Healing Formula